

6-1 Ball Chain Type Linear Guide

■ 6-1-1 Terms of Ball Chain Type Linear Guide

Main Factors

a. Lifetime and Load of Linear Guide (L)

Selection of linear guide has to be made on the static safety factor that is derived by comparing the calculated load of each carriage according to its conditions and forces against the factors such as basic static load rating (C_0) or permissible static moment (M_x , M_y , M_z) to judge the reliability of the mechanism. To estimate the lifetime in long term, the basic dynamic load rating (C) has to be considered to calculate the distance durability.

b. Basic Static Load Rating (C_0)

When the linear guide receives excessive load, the grooves and the steel balls will be permanently deformed. The linear guide will no longer operate smoothly when the deformation exceeds the limitation. The basic static load rating (C_0) is defined as the static load that will cause the deformation of the grooves and steel ball to 1/10,000 of the steel ball diameter.

c. Permissible Static Moment (M_x , M_y , M_z)

When the linear guide receives a moment, the grooves and the steel balls will deform. A moment that causes deformation of the grooves and the steel balls to 1/10,000 of the steel ball diameter is called the permissible static moment. The permissible static moment in the X, Y and Z directions are M_x , M_y and M_z individually.

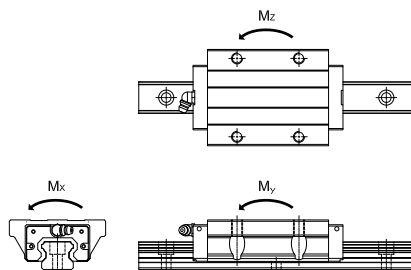


Fig. 6.1.1

d. Static Safety Factor (fs)

The static safety factor (fs) is the ratio of the basic static load rating (C₀) against the maximum equivalent load on the linear guide. This factor indicates the reliability of the linear guide. Applied load is the force applied to the groove. To calculate the equivalent load, we have to calculate the load applied to the carriage both vertical and parallel to the contact face of the groove. In the case of 4 symmetric loads at 45° contact, the equivalent load is the sum of the parallel load and the vertical load.

$$f_s = \frac{f_c \cdot C_0}{P} \quad f_s = \frac{f_c \cdot M_0}{M}$$

f_s : Static safety factor

f_c : Contact factor

C₀ : Basic static load rating

M₀ : Permissible static moment

P : Equivalent load

M : Equivalent moment

Static safety factor values :

Operations Conditions	Loading Conditions	Minimum f _s
Standing	Light impact and shift	1.0 ~ 1.3
	Heavy impact and twist	2.0 ~ 3.0
Operation	Light impact and twist	1.0 ~ 1.5
	Heavy impact and twist	2.5 ~ 5.0

e. Nominal Life (L)

Linear guide is a mass production product. Even though the products are manufactured with the same materials via the same processes, durability of individual linear guide is never the same even under the same operation conditions. Nominal life is the distance that 90% linear guides could travel without flaking under the designated conditions.

f. Basic Dynamic Load Rating (C)

If the life distance of certain linear guide is defined as 50 km, and if more than 90 % of the linear guides would last for 50 km under a load of constant direction and magnitude that without flaking owing to fatigue, then the load is defined as the basic dynamic load rating of this type of linear guide.

6-1 Ball Chain Type Linear Guide

Subsidiary Factors

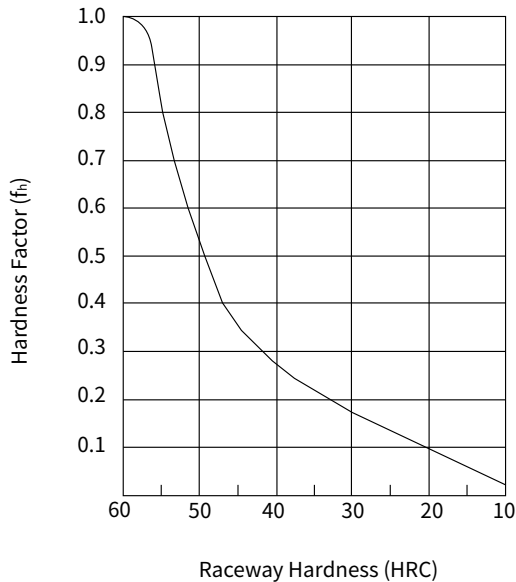
a. Contact Factor (f_c)

When carriages are arranged closely next to another, it is difficult to get even load distribution due to moment and the mounting accuracy. Hence, when multiple linear guides are used as a group, contact factor (f_c) should be brought into consideration.

Number of Carriages Used	Contact Factor (f_c)
2	0.81
3	0.72
4	0.66
5	0.61
Normal use	1

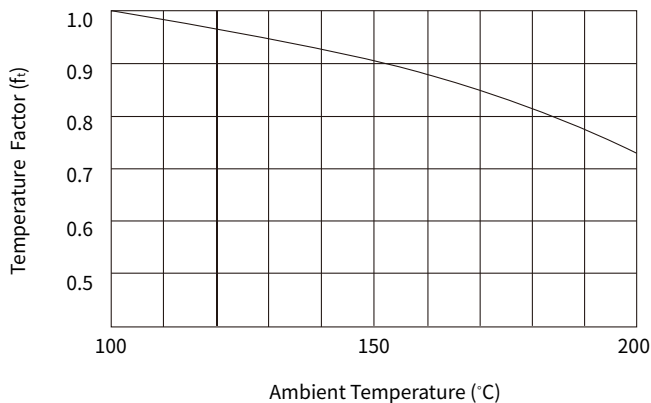
b. Hardness Factor (f_h)

To maximize the load capacity of the linear guide, the hardness of the raceways is the best in the range of HRC 58 to 62. If the hardness is lower than HRC 58, the hardness factor (f_h) should be brought into consideration when calculating the life distance and the safety factor.



c. Temperature Factor (f_t)

The adverse impact of high temperature must be considered while the ambient temperature exceeds 100°C. At this condition, the temperature factor (f_t) should be brought into calculation.



Note: If the ambient temperature exceeds 80°C, heat-resistant material must be used for the seals and the plastic parts.

d. Load Factor (f_w)

The operation of reciprocating mechanisms is easily inducing vibration or impact. Especially, the vibration caused by high-speed operation or inertial impact generated from the frequent turn on/off. One may refer to the experiential load factors (f_w) in the table below when calculating life distance under high speed or vibration.

Vibration / Impact	Speed (V)	Vibration (G)	Load Factor (f_w)
Weak	Low speed $V \leq 15$ m/min	$G \leq 0.5$	1~1.5
Medium	Moderate speed $15 < V \leq 60$ m/min	$0.5 < G \leq 1.0$	1.5~2.0
Strong	High speed $V > 60$ m/min	$1.0 < G \leq 2.0$	2.0~3.5

6-1 Ball Chain Type Linear Guide

Life Calculation Equation

Life distance (L) of linear guides can be calculated by applying the basic dynamic load rating (C) and the equivalent load (P) to the equation below:

$$L = \left[\frac{f_h \cdot f_t \cdot f_c}{f_w} \cdot \frac{C}{P} \right]^3 \cdot 50\text{km}$$

C: Basic dynamic load rating
 f_h: Hardness factor
 f_t: Contact factor
 P: Equivalent load
 f_t: Temperature factor
 f_w: Load factor
 L : Life distance(km)

When the life distance (L) is known, we can calculate the lifetime according to reciprocating stroke and frequency:

$$L_h = \frac{L \cdot 10^6}{2 \cdot L_s \cdot N_1 \cdot 60}$$

L_h= Lifetime (hr)
 N₁= Reciprocation frequency (cycles/min)
 L_s= Stroke (mm)

Friction

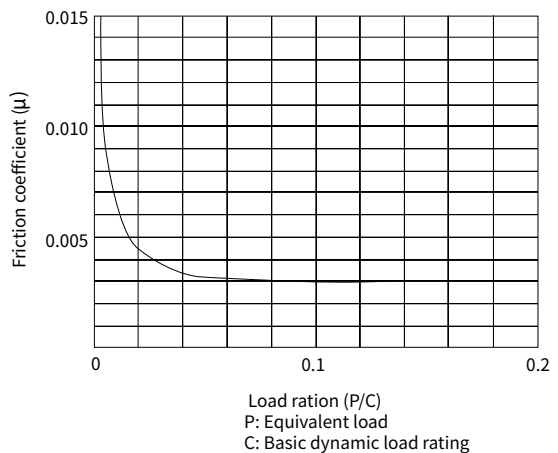
The linear guide is the integration of the carriage, the rail, and the rolling elements such as balls or rollers. Its movement is formed by the rolling elements rolling between the carriage and the rail, and the friction can be as minor as 1/40 of the sliding guide. The static friction of the linear guide is so small that the blank run phenomenon hardly occurs so it can be applied to all sorts of accurate applications. The friction of linear guide varies with the type of linear guide, the preload, the viscosity of lubricants, and the applied load. Friction increases especially when a moment is given or the preload is applied to increase rigidity. The friction characteristic of the linear guide is shown in table 6.1.1 below.

Friction can be calculated with the equation below,
 F=μ×W+f

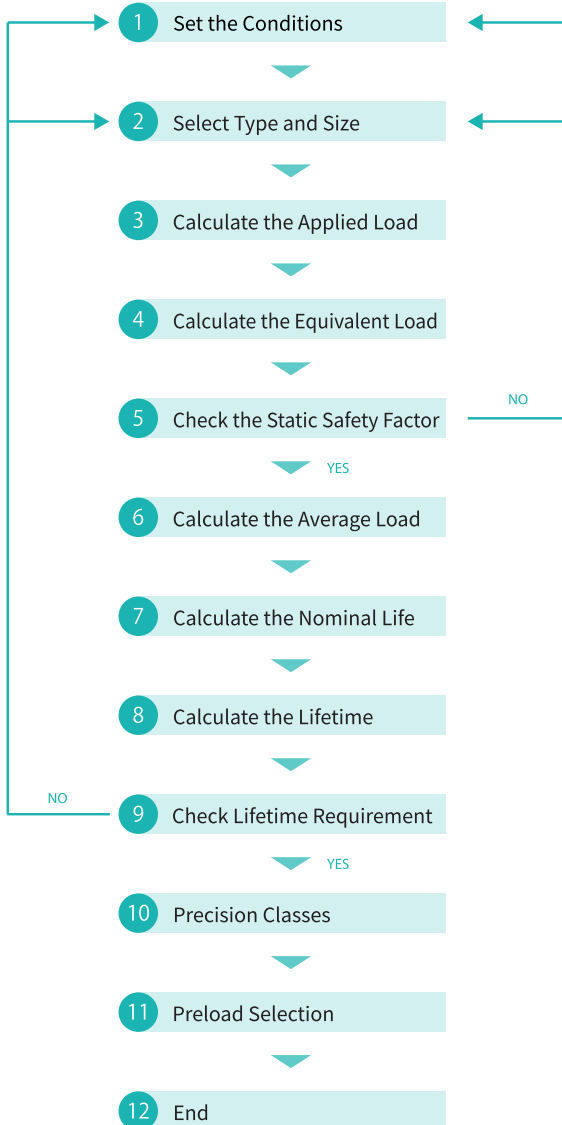
F: Friction
 W: Load
 μ: Friction coefficient
 f: Friction of carriage

Table 6.1.1 Friction coefficient (μ)

Type	Friction coefficient(μ)
CR Series	0.002~0.003



■ 6-1-2 Linear Guide Selection Steps

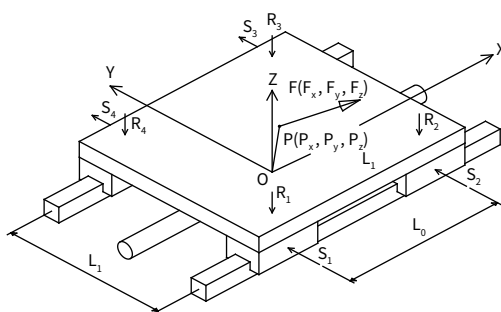


6-1 Ball Chain Type Linear Guide

1. Set the Conditions

Selection of linear guide has to be based on calculation. The information required for such calculation is:

- Mounting arrangements (span, number of carriages and number of rails)
- Mounting orientation (horizontal, vertical, slant mount, wall mount or inverted)
- Work load (magnitude, direction and applied point, and inertia under acceleration)
- Operation frequency (load cycle)



a. Installation Combination

(1)Span: distance between the carriages and the rails such as L_0 and L_1 in the above figure.

L_0 distance between the carriages on single rail. (Unit: mm)


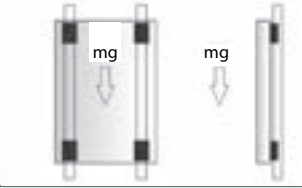
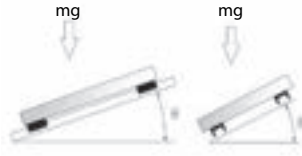
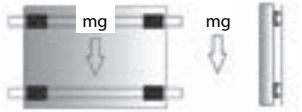
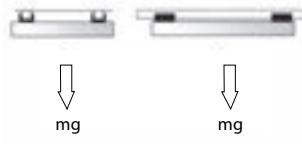
L_1 distance between two rails. (Unit: mm)

L_0 and L_1 are crucial to the rigidity and lifetime of the linear motion system.

(2)Number of carriages: how many carriages are mounted on the same rail. In the above figure, two carriages are mounted on one rail. Normally, loading capacity and rigidity are enhanced as the number of carriages increases, and so is the life. However, the operation space and the stroke must be considered.

(3)Number of rails: how many rails are used in the system. In the above figure, two rails are used in the system. Normally, in moment capacity is increased as the number of rails increase, and so are rigidity and life.

b. Mounting Orientation

1. Horizontal	
	<p>Horizontal</p> <p>This is the most common way of mounting. It is most persistent to vertical load (mg) and is often used in normal positioning and feeding mechanism. The load (mg) is parallel to the platform. The load (mg) is perpendicular to the direction of movement.</p>
2. Vertical	
	<p>Vertical</p> <p>The span in between the rails and the moment capacity are crucial. This is often seen in the elevator. Attention should be paid to the suspension of the load. The bigger the suspension is, the bigger the moment is. The load (mg) is parallel to the platform.</p>
3. Slant Mount	
	<p>Slant Mount</p> <p>There are lateral slant mount and longitudinal slant mount. Lateral slant mount: the load (mg) is vertical to the direction of movement. Longitudinal slant mount: the load (mg) is with an angle θ to the direction of movement.</p>
4. Wall Mount	
	<p>Wall Mount</p> <p>Moment is crucial for wall mount and the span in between rails affects the load on the carriages and must be taken care of. The load (mg) is parallel to the platform and vertical to the direction of movement.</p>
5. Inverted	
	<p>Inverted</p> <p>Inverted mount is upside down of horizontal mount. The spans in between the rails, carriages and the moment capacity have to be considered.</p>

6-1 Ball Chain Type Linear Guide

c. Work Load

The work load consists 3 elements - magnitude, direction and applied point.

1. Magnitude of work load:

Mass: The weight of the object gives inertia during movement.

External force: Mechanical forces such as hydraulic, pneumatic or electro-magnetic will not give inertia during the movement.

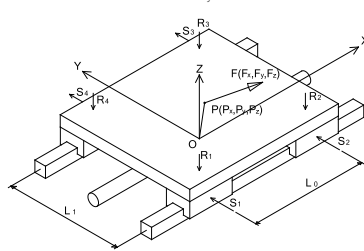
2. Direction of work load:

The external force can be divided into 3 components, F_x , F_y and F_z as indicated in the right figure.

F_x is the external force in the X-axis.

F_y is the external force in the Y-axis.

F_z is the external force in the Z-axis.



3. Applied point of work load:

As shown above figure, take Point "O" as the origin point of the XYZ coordinate. The source of external force can be a ball screw, a hydraulic cylinder or a linear motor.

The external force "F" applied on the object at point "P", then the applied point of the external force can be defined as:

P_x : Distance of applied point "P" to "O" in X axis.

P_y : Distance of applied point "P" to "O" in Y axis.

P_z : Distance of applied point "P" to "O" in Z axis.

4. Span:

L_0 and L_1 stand for the distances in between the carriages.

5. Velocity diagram:

Velocity (V): max operation velocity

Travel distance (D): total travel distance

Acceleration distance (D1): the distance from start to max velocity

Constant distance (D2): the distance in constant (max) velocity

Deceleration distance (D3): the distance from max velocity to stop

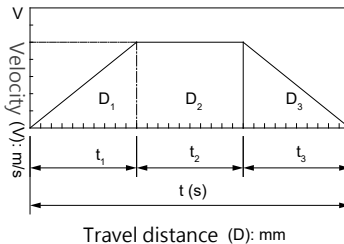


Fig. 6.1.2 Velocity Diagram

6. Work load on each carriage:

R_1, R_2, R_3 and R_4 are the vertical loads of each carriage.

S_1, S_2, S_3 and S_4 are the horizontal loads of each carriage.

d. Work Frequency:

To determine the lifetime is satisfied or not, the work frequency must be considered.

Ex. 1, if the calculated life is 1,000 km and the daily travel is 1 km, then the duration is 1,000 days.

Ex. 2, if the calculated life is 50,000 km and the daily travel is 500 km, then the duration is only 100 days.

2. Select Type and Size

a. Select the appropriate type (CR)

Select the appropriate series of linear guides according to the type of machine and the application. Please see our catalogues of CR series for relevant information.

b. Select an appropriate size

Select a size according to the installation space of machine without considering the work load. In the initial stage, it is difficult to judge load capacity and lifetime. Even if the safety factor is sufficient, it does not say that the lifetime is sufficient. Hence, it is recommended to consider the size as the initial selection objective, and then select the bigger type when life or load is insufficient in practice.

3. Calculate the Applied Load

The vertical forces on the carriages are:

$$R_1 = \frac{-F_z}{4} + \frac{F_z \cdot P_x - F_z \cdot P_z}{2 \cdot L_0} + \frac{F_z \cdot P_y - F_y \cdot P_z}{2 \cdot L_1}$$

$$R_2 = \frac{-F_z}{4} + \frac{F_z \cdot P_x - F_z \cdot P_z}{2 \cdot L_0} + \frac{F_z \cdot P_y - F_y \cdot P_z}{2 \cdot L_1}$$

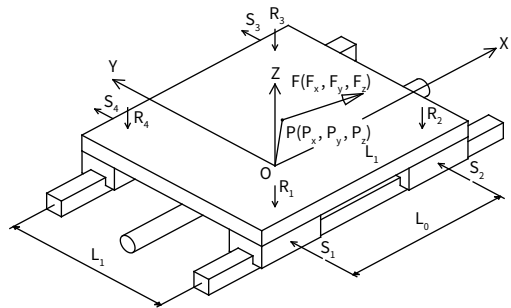
$$R_3 = \frac{-F_z}{4} + \frac{F_z \cdot P_x - F_z \cdot P_z}{2 \cdot L_0} + \frac{F_z \cdot P_y - F_y \cdot P_z}{2 \cdot L_1}$$

$$R_4 = \frac{-F_z}{4} + \frac{F_z \cdot P_x - F_z \cdot P_z}{2 \cdot L_0} + \frac{F_z \cdot P_y - F_y \cdot P_z}{2 \cdot L_1}$$

The horizontal forces on the carriages are:

$$S_1 = S_4 = \frac{F_y}{4} + \frac{F_y \cdot P_x - F_x \cdot P_y}{2 \cdot L_0}$$

$$S_2 = S_3 = \frac{F_y}{4} - \frac{F_y \cdot P_x - F_x \cdot P_y}{2 \cdot L_0}$$



6-1 Ball Chain Type Linear Guide

4. Calculate the Equivalent Load

The vertical and horizontal load capacities of a linear guide depend on the contact angle between the carriage and the rail. The contact angle of the linear guides is designed to be 45° to get equal load in the vertical and the horizontal direction. The equivalent load is the maximum effective load of the carriage against the raceway. Despite counteract, the equivalent load on the rail (Re) can be considered as the sum of vertical load magnitude (Rn) and horizontal load magnitude (Sn).

Vertical load: R_n

Horizontal load: S_n

The equivalent load can be calculated as: $R_e = |R_n| + |S_n|$

5. Check the Static Safety Factor

Definition of static safety factor:

Static safety factor calculation by static load rating:

$$f_s = \frac{f_c \cdot C_0}{R_e} = \frac{(\text{contact factor}) \cdot (\text{static load rating})}{\text{max. individual equivalent load}}$$

Static safety factor calculation by permissible static moment:

$$f_s = \frac{f_c \cdot C_0}{M} = \frac{(\text{contact factor}) \cdot (\text{permissible static moment})}{\text{calculated moment}}$$

Contact Factor:

When carriages are arranged tightly together, it is difficult to get even load distribution due to moment and assembly accuracy. Hence, when carriages are used tightly together, it is recommended to bring into consideration the contact factor (fc).

Number of Carriages Used	Contact Factor (fc)
2	0.81
3	0.72
4	0.66
5	0.61
Normal use	1

Reference static safety factor values

Operations Conditions	Loading Conditions	Minimum fs
Standing	Light impact and shift	1.0~1.3
	Heavy impact and twist	2.0~3.0
Operation	Light impact and twist	1.0~1.5
	Heavy impact and twist	2.5~5.0

6. Calculate the Average Load

Calculation of average load:

There are several methods to calculate average load according to work load variation pattern in movement.

Stepwise load variation:

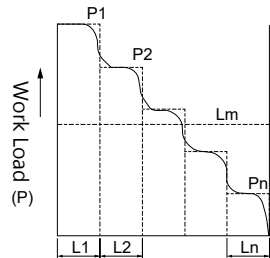
P_m : Average load (N)

P_n : Varying load (N)

L: Total travel distance (m)

L_n : Travel distance of each step (m)

$$P_m = \left[\frac{(P_1^3 \cdot L_1 + P_2^3 \cdot L_2 + \dots + P_n^3 \cdot L_n)}{L} \right]^{\frac{1}{3}}$$



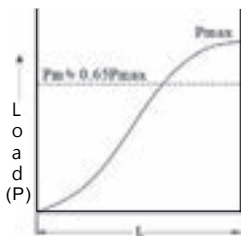
Total Travel distance (L)

Monotonic load variation:

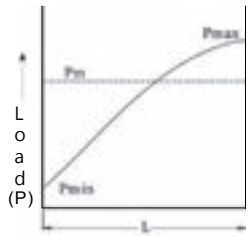
$$P_m \approx \left(\frac{P_{\min} + 2P_{\max}}{3} \right)$$

P_{\min} : minimum load (kgf)

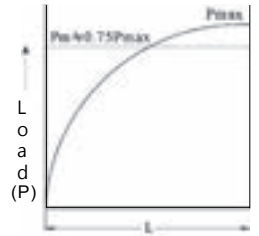
P_{\max} : maximum load (kgf)



Total Travel distance(L)



Total Travel distance (L)



Total Travel distance(L)

6-1 Ball Chain Type Linear Guide

7. Calculate the Nominal Life

$$L = \left[\frac{f_h \cdot f_t \cdot f_c}{f_w} \cdot \frac{C}{P} \right]^3 \cdot 50 \text{ km}$$

L: Nominal life (km)
C: Basic dynamic load rating (kN)
P: Calculated average load (kN)
 f_c : Contact factor
 f_h : Hardness factor
 f_t : Temperature factor
 f_w : Load factor

8. Calculate the Lifetime

Equation (A): Lifetime by Hours

$$L_h = \frac{L \cdot 10^6}{2 \cdot L_s \cdot N_1 \cdot 60}$$

L_h : Lifetime (h)
L: Nominal life (km)
 L_s : Stroke length (mm)
 N_1 : Reciprocations per minute (min^{-1})

Equation (B): Lifetime by Years

$$L_y = \frac{L \cdot 10^6}{2 \cdot L_s \cdot N_1 \cdot M \cdot H \cdot D}$$

L_y : Lifetime (year)
L: Nominal life (km)
 L_s : Stroke length (mm)
 N_1 : Reciprocations per minute (min^{-1})
M: Work minutes per hour (min/hr)
H: Work hours per day (hr/day)
D: Work days per year (day/year)

9. Check Lifetime Requirement

If the calculated lifetime does not meet the lifetime requirement, return and start from the beginning steps:

(1) Check the conditions again:

- a. Mounting arrangements (span, number of carriages and number of rails): Is it necessary to change the span, the number of carriages or the number of rails?
- b. Mounting position (horizontal, vertical, slant mount, wall mount or inverted): Is it necessary to modify current construction?
- c. Work load: Can the load be reduced?
- d. Work Frequency: Was the estimated usage frequency lower than the actual usage, resulting in a calculated lifetime shorter than the required lifetime?

(2) Select type and size:

If the conditions cannot be changed, then another type of linear guide has to be selected. It is recommended to keep the size of rail, and select a carriage with higher load rating.

Selecting a bigger rail may cause some drawbacks below:

a. The weight of the mechanism will be increased:

The weight increases more when selecting a bigger rail rather than selecting a carriage with higher load rating.

b. More changes in design:

When a bigger rail is selected,

1. The pitch of screw hole increased,
2. The screw size is bigger,
3. Contact area with base is increased,
4. The fastening mechanism has to be changed.

When a carriage with higher load rating is selected,

1. The span of screw holes have to be changed,
2. The length of the carriage may cause interference with mechanism.

c. More space is needed:

When a bigger rail is selected,

1. The total height is increased,
2. The total width is increased,
3. The fastening screw is bigger.

When a carriage with higher load rating is selected, the change of space will be little.

d. Cost will be increased:

The variable cost of the rail is higher than that of the carriage.

6-1 Ball Chain Type Linear Guide

10. Precision Classes

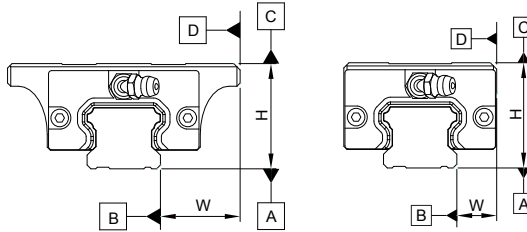


Fig. 6.1.3 Precision Classes

Table 6.1.2 Precision classes of non-interchangeable linear guide for CR series

Unit: mm

Item \ Grade	Normal (N)	High (H)	Precision (P)	Super Precision (SP)	Ultra Precision (UP)
Height tolerance (H)	±0.1	±0.04	0 -0.04	0 -0.02	0 -0.01
Width tolerance (W)	±0.1	±0.04	0 -0.04	0 -0.02	0 -0.01
Height difference(Δ H)	0.03	0.02	0.01	0.005	0.003
Width difference(Δ W)	0.03	0.02	0.01	0.005	0.003
Running parallelism between carriage surface C and the rail surface A	Δ C Refer to Running parallelism vs. rail (CR Series) length				
Running parallelism between the carriage reference surface D and the rail reference surface B	Δ D Refer to Running parallelism vs. rail (CR Series) length				

※ Height difference (Δ H) refers to the difference between the maximum and minimum height dimensions of the blocks on the same rail.

※ Width difference (Δ W) refers to the difference between the maximum and minimum width dimensions of the blocks on the same rail.

Table 6.1.3 Precision classes of interchangeable linear guide for CR series

Unit: mm

Item \ Grade	Normal (N)	High (H)
Height toleranc (H)	±0.1	±0.04
Width tolerance (W)	±0.1	±0.04

※ Definition of interchangeable: For the carriages on a single rail, not including the carriages on different rails.

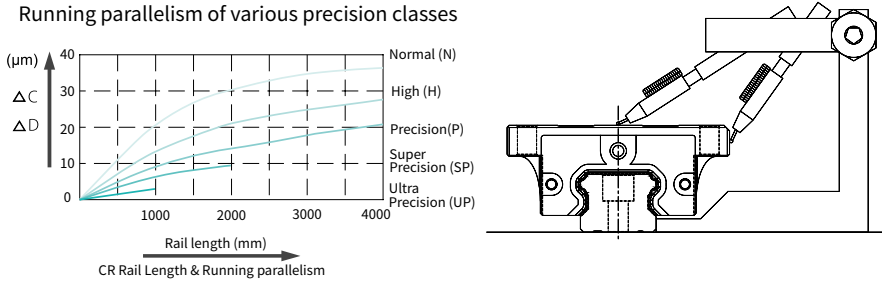


Fig. 6.1.4 Running parallelism vs. rail length

Notes:

1. Please contact us if SP (super precision) rail over 2000mm or UP (ultra precision) rail over 1000mm is required.
2. To make it easier to gain the required precision when mounting the rails against the datum plane, the rails are made slight curved with a big radius.
3. If the datum plane is non-rigid, machine accuracy is easily affected when mounting rails. Hence, it is necessary to inquire straightness of the rails.

Unit: mm/ μ m

Standard Type						
Rail Length (mm)		Running Parallelism Values (μ m)				
Minimum	Maximum	N	H	P	SP	UP
0	100	12	7	3	2	2
100	200	14	9	4	2	2
200	300	15	10	5	3	2
300	500	17	12	6	3	2
500	700	20	13	7	4	2
700	900	22	15	8	5	3
900	1100	24	16	9	6	
1100	1500	26	18	11	7	
1500	1900	28	20	13	8	
1900	2500	31	22	15		
2500	3100	33	25	18		
3100	3600	36	27	20		
3600	4000	37	28	21		

6-1 Ball Chain Type Linear Guide

11. Preload Selection

What is preload?

When there is clearance between the components, the rigidity of linear guide is not enough.

It is possible to eliminate the clearance by enlarging the rolling elements to preliminarily apply an internal load to enhance the rigidity.

Table 6.1.4 Preload grade

Preload grade	Slight clearance / No preload	Light preload	Medium to heavy preload
Conditions	1. low impact 2. two rails in parallel 3. low accuracy 4. small friction 5. light load	1. cantilever 2. single rail usage 3. light load 4. high accuracy	1. strong impact 2. strong vibration 3. heavy machining
Applications	1. welding machine 2. chopping machine 3. feeding mechanism 4. tool change mechanism 5. ordinary XY table 6. packing machine	1. NC lathe 2. Electrical discharge machining 3. precision XY table 4. ordinary Z-axis 5. industrial robot 6. PCB punching	1. Machining center 2. NC lathe and miller 3. feeding axis of grinder 4. tool feeding axis

Increase the preload will eliminate the vibration and the inertia impact in a reciprocating movement. However, increase of preload will increase the internal load and increase the assembly difficulty. Therefore, selection of linear guide must bring into account the balance between the impact of vibration and the lifetime decrease by preload.

Table 6.1.5 Radial clearance

Unit : μm

Preload Type	ZF	Z0	Z1	Z2	Z3
CR 15	4 ~ 8	-3 ~ 3	-8 ~ -4	-13 ~ -9	-18 ~ -14
CR 20	4 ~ 8	-3 ~ 3	-8 ~ -4	-14 ~ -9	-19 ~ -14
CR 25	5 ~ 10	-4 ~ 4	-10 ~ -5	-17 ~ -11	-23 ~ -18
CR 30	5 ~ 11	-4 ~ 4	-11 ~ -5	-18 ~ -12	-25 ~ -19
CR 35	6 ~ 12	-5 ~ 5	-12 ~ -6	-20 ~ -13	-27 ~ -20
CR 45	7 ~ 15	-6 ~ 6	-15 ~ -7	-23 ~ -15	-32 ~ -24
CR 55	8 ~ 19	-7 ~ 7	-19 ~ -8	-29 ~ -20	-38 ~ -30

Table 6.1.6 Preload values

C: Basic dynamic load rating

Grade	Code	Preload
Slight clearance	ZF	0
No preload	Z0	0
Light preload	Z1	0.02C
Medium preload	Z2	0.05C
Heavy preload	Z3	0.07C

※If special preload is needed, please contact us for technical service.

Table 6.1.7 Comparison of interchangeable and non-interchangeable

Precision class	Non-interchangeable type					Interchangeable Type	
	UP	SP	P	H	N	H	N
Preload					ZF		
				Z0	Z0	Z0	Z0
	Z1	Z1	Z1	Z1	Z1	Z1	Z1
	Z2	Z2	Z2	Z2	Z2		
	Z3	Z3	Z3				

Permitted installation tolerance:

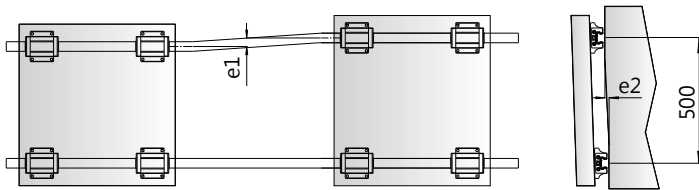


Table 6.1.8 Allowance of installation deviations

Unit : μm

Type	Allowance of parallel deviation (e1)					Allowance of level deviation (e2)				
	Z3	Z2	Z1	Z0	ZF	Z3	Z2	Z1	Z0	ZF
CR 15			18	25	35			85	130	190
CR 20		18	20	25	35		50	85	130	190
CR 25	15	20	22	30	42	60	70	85	130	195
CR 30	20	27	30	40	55	80	90	110	170	250
CR 35	22	30	35	50	68	100	120	150	210	290
CR 45	25	35	40	60	85	100	140	170	250	350
CR 55	30	45	50	70	95	125	170	210	300	420

※ The defined values of the allowed parallel deviation and level deviation are shown in table 6.1.8. The standard is based on the 500 mm wheelbase.

6-1 Ball Chain Type Linear Guide

Dust Proof of Rails

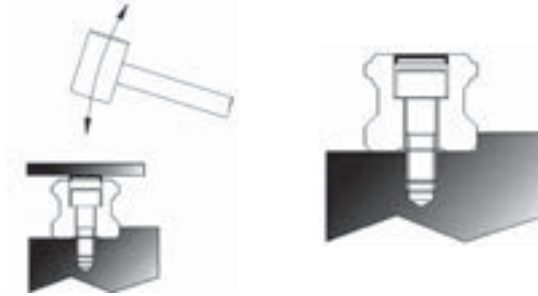


Fig. 6.1.5 Dust proof bore cap

Rail Contamination:

In the machines built with linear guides, chips and foreign objects pile up easily in the rail bores to get inside the carriages. These chips and particles can block the ball circulation and shorten the life of the linear guides.

Bore Cap:

Most chips and foreign objects that fall on the rails can be wiped away by the end seals. Only few accumulate in the bores. The purpose of the rail caps is to block the objects from falling into the bores. These caps can be easily mounted with plastic mallet or plastic panel aligned with bore after rail is secured.

Mounting from Bottom Rails:

These rails are fastened differently from the conventional rails. Since there are no exposed countersunk bores on top, dust and chips simply cannot be stocked.

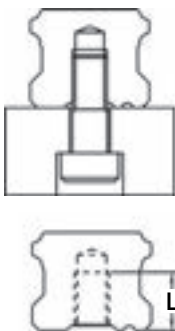


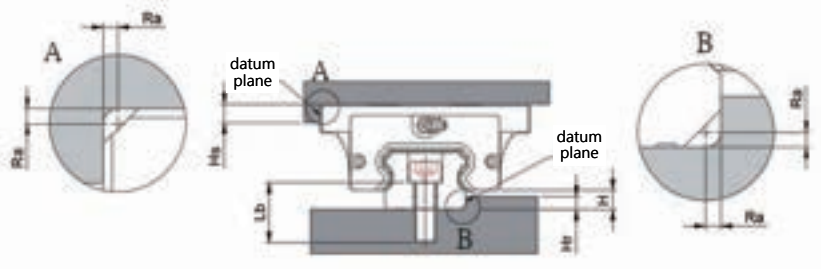
Table 6.1.9 Specification of bolts

Unit : mm

Rail Type	Thread Size	Max thread length (L)
CR15	M5x0.8	8
CR20	M6x1.0	10
CR25	M6x1.0	12
CR30	M8x1.25	15
CR35	M8x1.25	17
CR45	M12x1.75	20
CR55	M14x2.0	24

■6-1-3 How to Install Linear Guide

Installation Design Concept



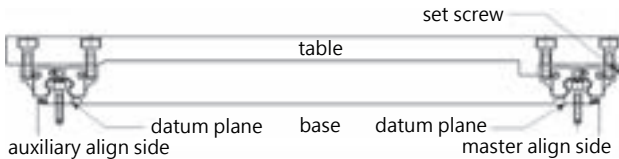
Shoulder height and corner radius of the base

One side of the rail and the carriage is the datum plane for installation and position of linear guide. Datum plane is chamfered both in the rail and in the carriage to avoid interference with the base. It is recommended to design the base shoulder with the dimension in the table below:

Unit : mm

Type	Max. corner radius of align shoulders (Ra)	Height of rail align shoulder (Hr)	Height of carriage align shoulder (Hs)	H
CR 15	0.6	3.1	5	3.3
CR 20	0.9	4.3	6	4.5
CR 25	1.1	5.6	7	5.8
CR 30	1.4	6.8	8	7
CR 35	1.4	7.3	9	7.5
CR 45	1.6	8.7	12	8.9
CR 55	1.6	11.8	17	12.7

Linear guide installation steps



Above picture shows a typical example for rail installation with the features below,

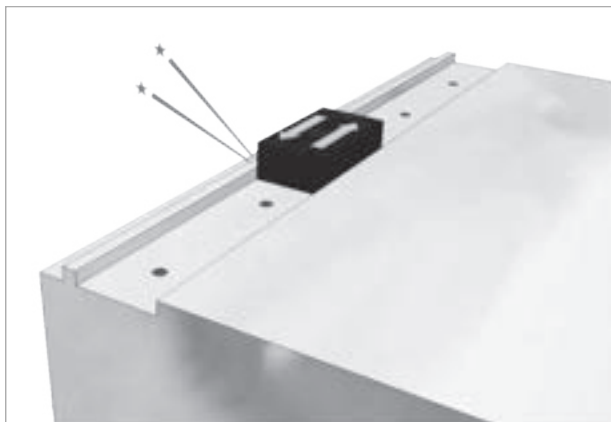
1. There are two datum planes for rail installation on the base.
2. There is set screw in the table to position the table laterally.
3. The set screw in the table is at the master align side.

6-1 Ball Chain Type Linear Guide

Installation Steps

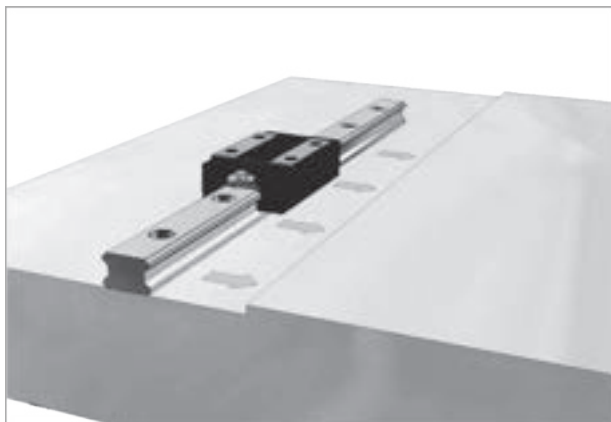
Step 1 All burrs, contaminations and marks must be removed before installation.

Attention: Datum plane is normally covered with antirust oil. Clean the antirust oil with cleaners before installation. Datum plane will get rusty easily without antirust oil, hence, it is recommended to spray some low viscosity lubricant to protect the datum plane from rusting.



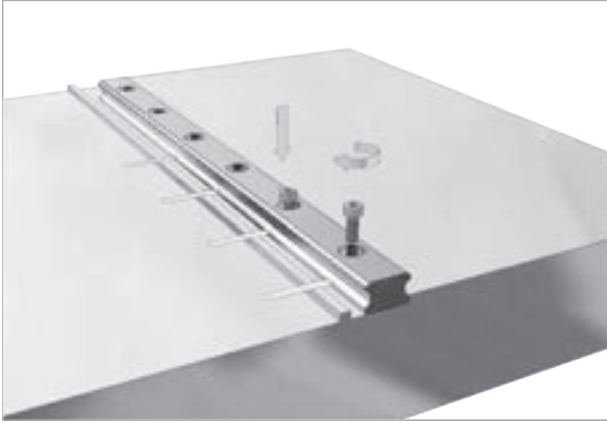
Step 2 Place the master rail gently on the base and make sure it contacts the datum plane nicely with set screws or other fixtures.

Attention: Check the alignment of the screw holes before securing. Fastening the rail with unaligned screw holes will affect the accuracy and quality due to offset or deformation.

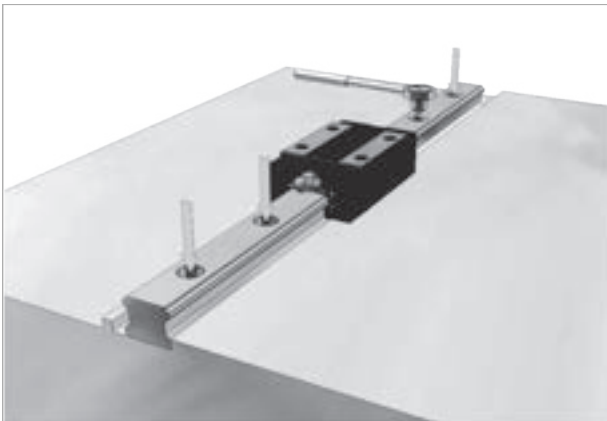


Step 3 Attach the screws to screw holes in the sequence from center to both ends and push the rail gently against the datum plane.

Attention: Fasten the screws in the sequence from center to both ends adequately to make the rail more stable. When the rail is stable in place, enhance the lateral force so that the rail adjoins the datum plane properly.



Step 4 Fasten the screws by a torque wrench with the appropriate torque according to the screw size and base material.



6-1 Ball Chain Type Linear Guide

Recommended rail screw fastening torque

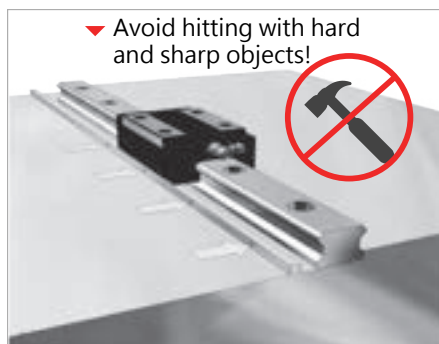
Unit : kgf-cm

Screw size	Fastening torque (kgf-cm)		
	Steel	Cast Iron	Aluminum alloy
M 2	6.3	4.2	3.1
M 2.3	8.4	5.7	4.2
M 2.6	12.6	8.4	6.3
M 3	21	13.6	10.5
M 4	44.1	29.3	22
M 5	94.5	63	47.2
M 6	146.7	98.6	73.5
M 8	325.7	215.3	157.5
M 10	724.2	483.2	356.7
M 12	1264.2	840	630
M 14	1682.1	1125	840
M 16	2100	1403.5	1050

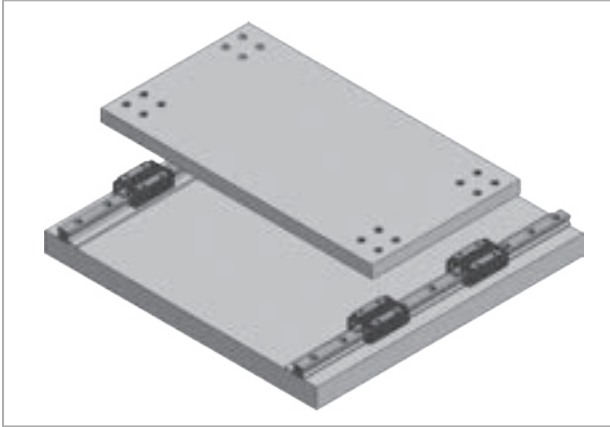
※Please select the appropriate torque according to base material and screw size, and fasten the rail screw gently with the torque wrench.

Step 5 Install the slave rail with the same steps foresaid, then install the carriages onto the rails individually.

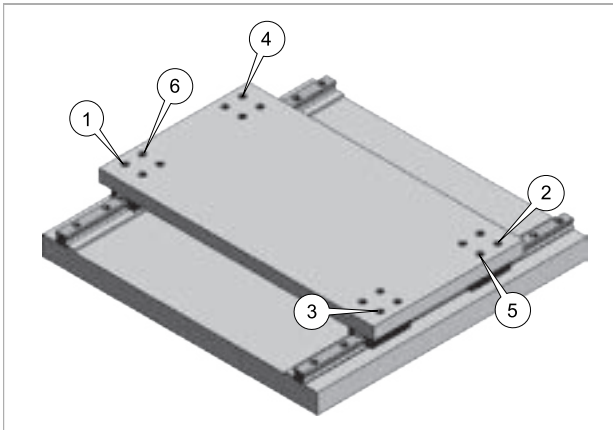
Attention: Space can be very limited and makes it difficult to assembly the accessories after carriage is installed on the rail. Hence, it is recommended to assembly all accessories, such as grease nipple, oil fitting and seals at this stage.



Step 6 Place the table gently on the carriages on both master and slave rails.

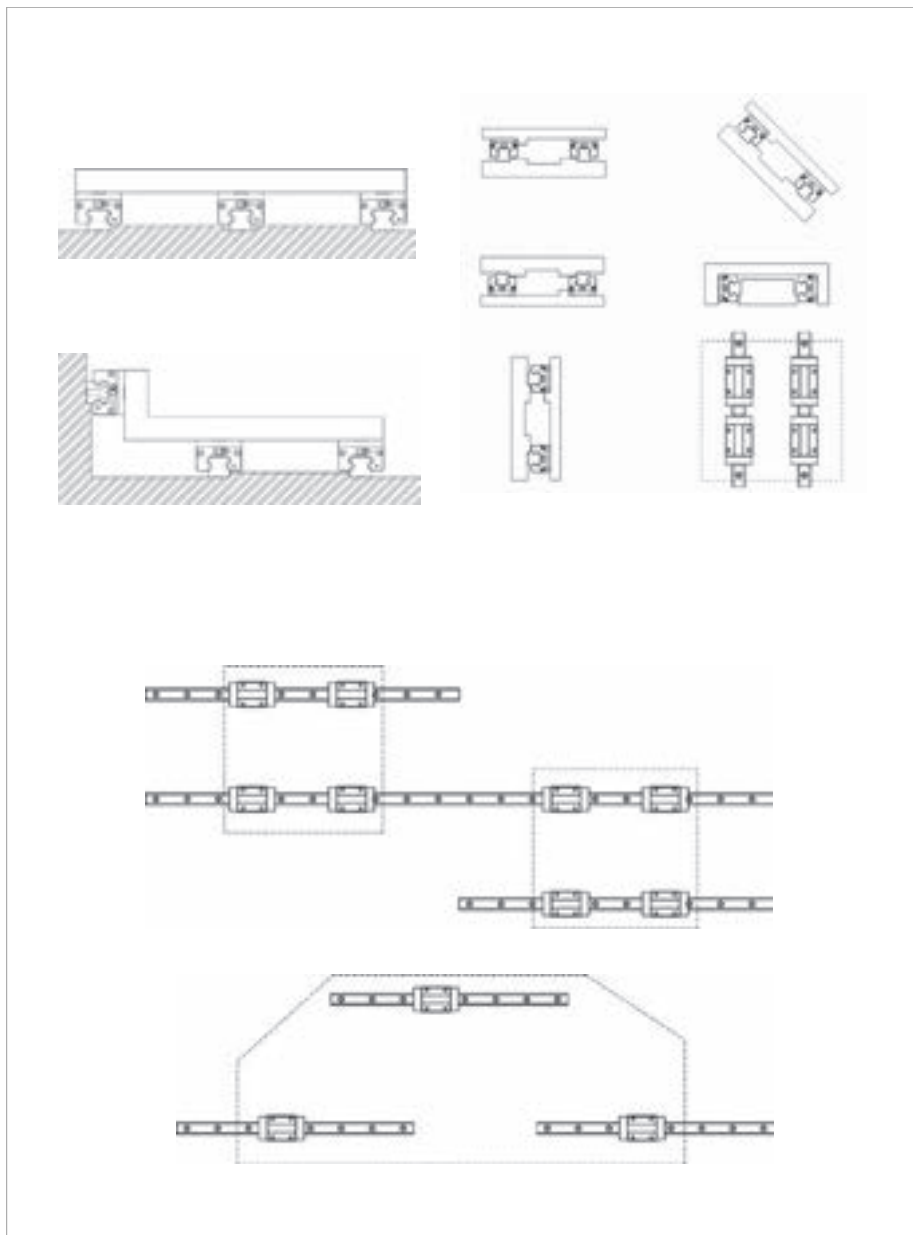


Step 7 Fasten the crosswise set screw to secure the table. Fasten the table screws with the sequence demonstrated in the figure below

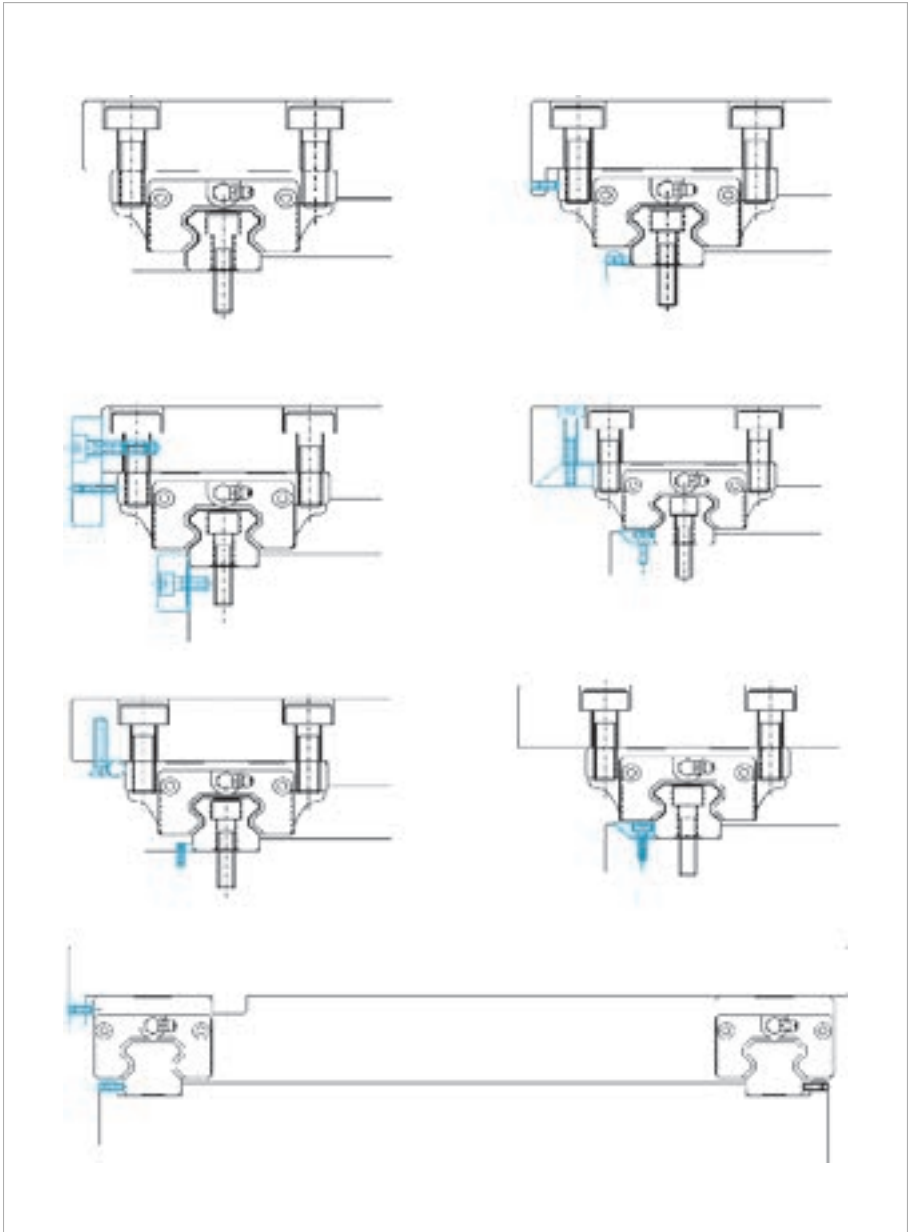


6-1 Ball Chain Type Linear Guide

Common Installation Patterns



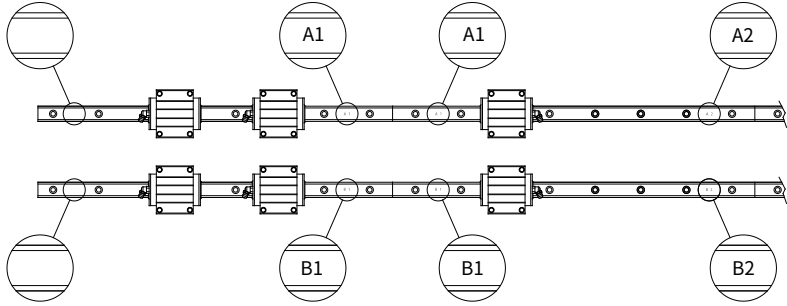
Common Securing Methods



TBI MOTION LINEAR GUIDE

6-1 Ball Chain Type Linear Guide

Use of Jointed Rails

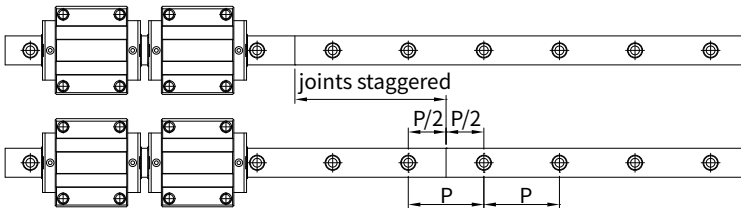


When an over length rail is required, two or more rails can be butt-jointed to the required length. When jointing rails, be sure to match the marked positions correctly as the above figure.

The linear guides will be numbered as the table below:

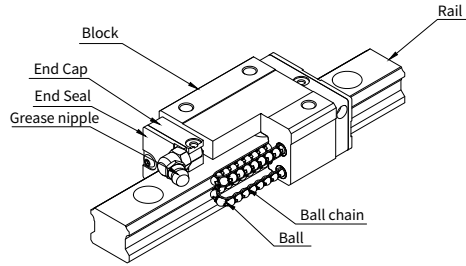
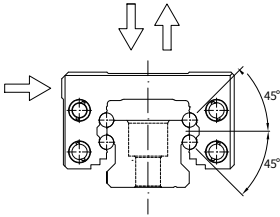
	Jointed rail #1	Jointed rail #2	Jointed rail #3	...	Jointed rail #N
Parallel axis #01	No mark A1	A1 A2	A2 A3	A3 ...	AN No mark
Parallel axis #02	No mark B1	B1 B2	B2 B3	B3 ...	BN No mark
...	⋮	⋮	⋮	⋮	⋮
Parallel axis #26	No mark Z1	Z1 Z2	Z2 Z3	Z3 ...	ZN No mark

If two jointed rails are used in pair, in order to minimize the deviation, it is recommended to stagger the joint points in these two rails.

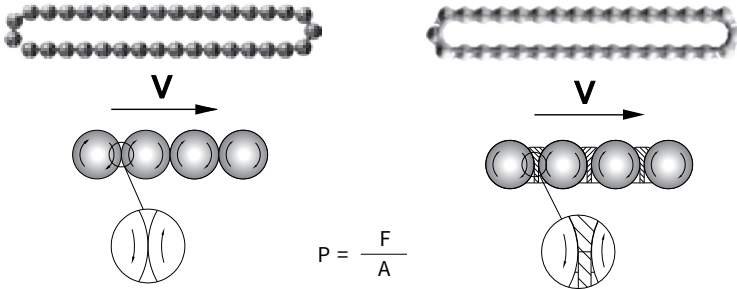


■ 6-1-4 CR Series Ball Chain Linear Guide

Introduction to ball chain



In CR series, the steel balls do not come into direct contact with one another. In contrast, conventional linear guides have steel balls that make point contact at two small spots, which results in significantly higher contact pressure on the linear guide. Because CR series uses a ball chain, an oil film is maintained between balls, and the relative frictional speed is only about half that of conventional linear guides. Considering both frictional speed and contact pressure, the heat generation of CR series is therefore lower than that of conventional linear guides.



P: Contact pressure of steel balls

F: Interaction force of steel balls

A: Contact area of steel balls

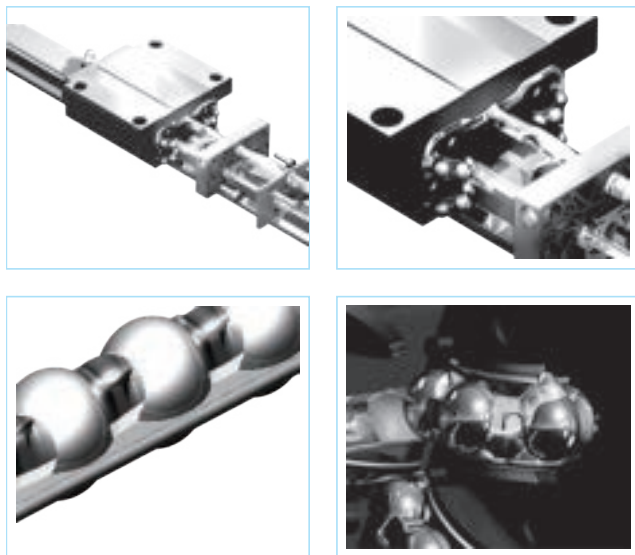
As shown in the upper left figure, Conventional linear guide: The relative speed is double of rotation speed and the pressure is almost infinity owing to the contact area is extremely small.

As shown in the upper right figure, CR series linear guide: Ball chain provide better lubrication and absorbed the friction between steel balls that allows the carriage move in high speed.

6-1 Ball Chain Type Linear Guide

a. Lubrication by Circulation

The lubricant can be injected via the grease nipples and its effect can be enhanced by the ball chain circulation in CR series.



As shown in the figure, the oil film stays between the steel balls and the ball chain.

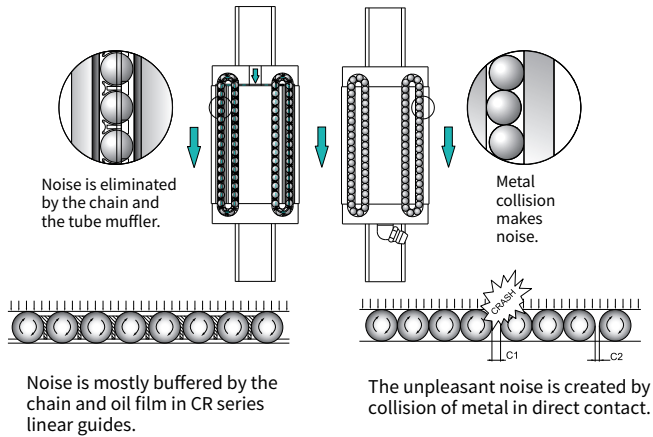
This unique chain design of CR series linear guides provides more space to reserve the lubricant. The ball chain brings the lubricant to every circulation surface as it circulates. Even when resting, less lubricant escapes from CR series linear guides than the conventional linear guide.

In conventional linear guides, the lubrication oil vanishes easily as they run. Loss of lubrication oil results in wearing, noise and heating. CR series linear guide was design to solve this issue and improves the performance and life effectively.

b. Less Noisy

The conventional linear guides are noisier because:

1. Relative speed at steel ball contact is twice than that of motion speed.
2. The contact area is too small that enlarge the contact pressure as well as the friction.



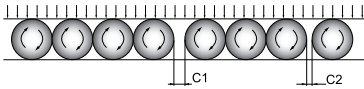
When the steel balls travel in different speeds, circulation will cause chasing in the steel balls. In the conventional linear guides, collisions of steel balls create loud noises. The macromolecular polymer chain of CR series linear guides is designed with rooms to retain lubrication oil. Most collision noises are eliminated by the elasticity of the chain and the oil film buffering.

TBI MOTION LINEAR GUIDE

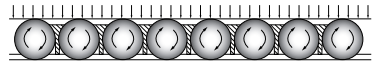
6-1 Ball Chain Type Linear Guide

c. Evenly Load Distributed


The steel balls in conventional linear guides cannot be evenly distributed to get even clearances between steel balls, so the load on each steel ball is uneven. This uneven load shortens the lifetime of steel balls in a long time. In CR series linear guides, the steel balls fixed by the chain are evenly distributed in the circulation runway and are evenly loaded so the lifetime is more reliable.



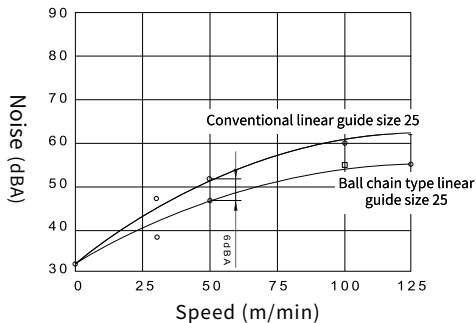
As shown in the figure above: Steel balls are randomly distributed in the conventional linear guides and unevenly loaded.



As shown in the figure above: Steel balls are fixed by the chain in CR linear guides. It minimizes the uneven clearance to guarantee a more reliable lifetime.



This extra steel ball permits a much smoother circulation.



d. CR series Ball Chain Type vs. Conventional Linear Guides



	Conventional linear guides	CR series Ball chain type linear guides
Maintenance	Oil film not easy to maintain	Oil film easy to maintain
Noise	Noisy	Quiet
Heating	High	Low
Load	Uneven	Even

TBI MOTION LINEAR GUIDE

6-1 Ball Chain Type Linear Guide

■ 6-1-5 Nominal Model Code for Non-interchangeable CR Type

C R H 20 F N - 2 - - 1200 - N - Z0 - II - K + N3 N3

① ② ③ ④ ⑤ ⑥ ⑦ ⑧ ⑨ ⑩ ⑪ ⑫ ⑬ ⑭ ⑮

① Nominal Model	② Block Type	③ Height of Assembly Type	④ Dimension
C	R: Standard X: Special	S: Low-Assembly H: High-Assembly	15、20、25、30、35、45、55

⑤ Flange Type	⑥ Length of Block	⑦ Number of Block per Rail	⑧ Accessory Code
F: With Flange V: Without Flange	S: Short N: Normal L: Long E: Extra-Long	EX: 2	Standard (Please refer to page A164)

⑨ Length of Rail	⑩ Accuracy Grade	⑪ Preload	⑫ Two Sets per Axis
Unit :mm	N: Normal H: High P: Precision SP: Super-Precision UP: Ultra-Precision	ZF: Slight Clearance Z0: No Preload Z1: Light Preload Z2: Medium Preload Z3: Heavy Preload	II

⑬ Rail Special Machining	⑭ Block Surface Treatment	⑮ Rail Surface Treatment
□: Mounting from Top K: Mounting from Bottom X: Rail with Special Machining	□: Standard N1: Hard Chrome Plating N3: Nickel Plating N4: Raydent (Fluoride chromium) N5: Chrome Plating	□: Standard N1: Hard Chrome Plating N3: Nickel Plating N4: Raydent (Fluoride chromium) N5: Chrome Plating

- ※ No Symbol required when plating is not needed.
- ※ The block with ball chain is only suitable for CR series rails.

■ 6-1-6 Nominal Model Code for Interchangeable CR Type

Interchangeable Type of Block



①	②	③	④
Nominal Model	Block Type	Height of Assembly Type	Dimension
C	R: Standard X: Special	S: Low-Assembly H: High-Assembly	15、20、25、30、35、45、55

⑤	⑥	⑦	⑧
Flange Type	Length of Block	Accessory Code	Accuracy Grade
F: With Flange V: Without Flange	S: Short N: Normal L: Long E: Extra-Long	Standard (Please refer to page A164)	N: Normal H: High

⑨	⑩
Preload	Block Surface Treatment
ZF: Slight Clearance	□: Standard
Z0: No Preload	N1: Hard Chrome Plating
Z1: Light Preload	N3: Nickel Plating
	N4: Raydent (Fluoride chromium)
	N5: Chrome Plating

※ The block with ball chain is only suitable for CR series rails.

TBI MOTION LINEAR GUIDE

6-1 Ball Chain Type Linear Guide

Interchangeable Type of Rail

C **R** **20** - **1200** - **N** - **K** + **N3**

① ② ③ ④ ⑤ ⑥ ⑦

①	②	③	④
Nominal Model	Block Type	Dimension	Length of Rail
C	R: Standard X: Special	15 · 20 · 25 · 30 · 35 · 45 · 55	Unit: mm

⑤	⑥	⑦
Accuracy Grade	Rail Special Machining	Rail Surface Treatment
N: Normal H: High	□: Mounting from Top K: Mounting from Bottom X: Rail with Special Machining	□: Standard N1: Hard Chrome Plating N3: Nickel Plating N4: Raydent (Fluoride chromium) N5: Chrome Plating

※ The block with ball chain is only suitable for CR series rails.

Accessory Code

Accessory	Code								Add "A" after each code
	XNB	UNB	DUB	ZNB	SUB	SZB	ZUB	DSB	
End Seal	○	○			○		○		
Two End Seals			○	○		○		○	
Top Seal		○		○	○	○			
Bottom Seal	○	○	○	○	○	○	○	○	
Metal Scraper					○	○	○	○	
Self-Lubrication									○

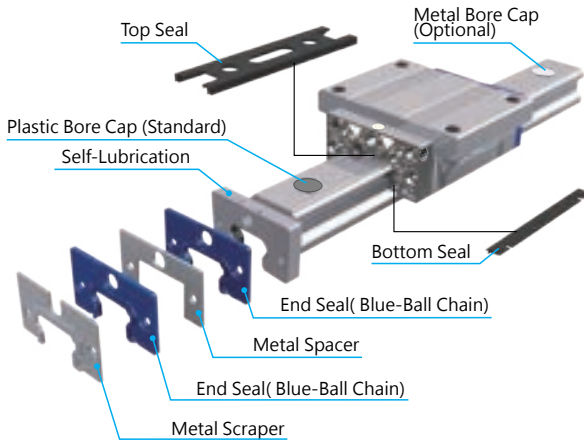
■6-1-7 Dust-proof Accessory

CR Series Dust-proof Design

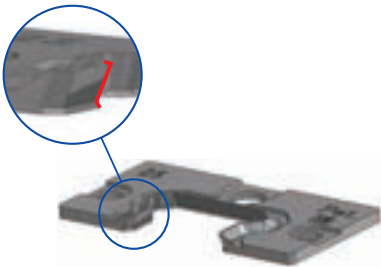
Incursion of foreign particles is the main reason of shorter rail life because accuracy of linear guide relies very much on the precision of rail, carriage and steel balls. Even the tiniest particle in the circulation runway can cause abnormal vibration and bumping of the linear guide and lead to permanent damage. Therefore, dust-proof is the key to improve the quality of linear guide.

Passages for particle incursion:

1. Bores: Dust accumulates easily at the rail bores and get into the circulation runway due to vibration or machine movements.
2. Gap between carriage and rail: Bigger particles normally incurs from the gap between carriage and rail that is the closest to the runway.



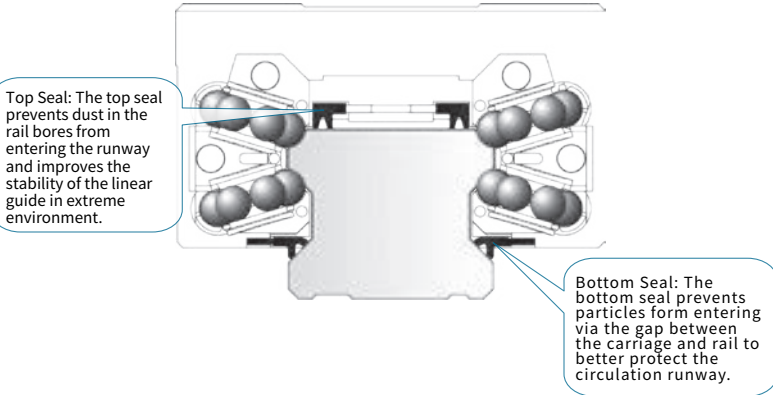
End Seal



Strength

1. Lighter friction
2. Good dust-proof performance
3. Smooth running

6-1 Ball Chain Type Linear Guide



A

Linear Guide

Top Seal

Top seal aims at dust accumulated in the rail bores. It stops the dust from entering the circulation runway with the lips to separate the rail bores.



Bottom Seal

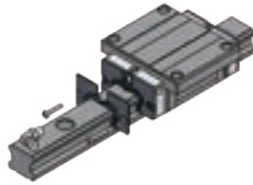
Bottom seal aims at the gap between carriage and rail. It closes the gap with the wiper to prevent dust getting into the circulation runway from aside and underneath.



Nylon applied and fit closely with the rail surface, which blocks the dust effectively.

Metal Scraper

It is applicable for metal cutting machines or flame cutting machines to scrape bigger chips or welding spatters. It protects the end seal from being damaged by sharp chips or burning spatters so that the end seal will keep its dust-proof function.



6-1 Ball Chain Type Linear Guide

Dust-proof Systems

Standard System

The double-lip end seal ensures that the dust and particles will be kept of the carriage by the inner lip to secure performance even if the outer lip is worn out. It is recommended for the environment with much powder and chips.

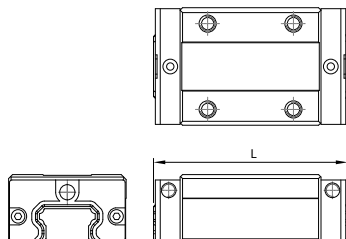


Table 6.1.10 Length of CR series Block with Accessory

Unit: mm

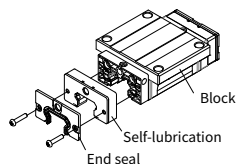
End Seal+Bottom Seal (XNB) / End Seal+Top Seal+Bottom Seal (UNB)								
Length of Block \ Size	CR15	CR20	CR25	CR30	CR35	CR45	CR55	
S	40.6	49.1	54	64.2	75.5			
N	58.6	70.1	79.2	94.8	111.5	129	155	
L	66.1	82.9	93.9	105	123.5	145	193	
E		98.1	108.6	130.5	153.5	174	210	
Two End Seals+Bottom Seal (DUB) / Two End Seals+Top Seal+Bottom Seal (ZNB)								
Length of Block \ Size	CR15	CR20	CR25	CR30	CR35	CR45	CR55	
S	46.6	56.1	61	72.2	84.5			
N	64.6	77.1	86.2	102.8	120.5	139	165	
L	72.1	89.9	100.9	113	132.5	155	203	
E		105.1	115.6	138.5	162.5	184	220	
End Seal+Top Seal+Bottom Seal+Metal Scraper (SUB) / End Seal+Bottom Seal+Metal Scraper (ZUB)								
Length of Block \ Size	CR15	CR20	CR25	CR30	CR35	CR45	CR55	
S	42.4	51.5	56.9	66.8	78.1			
N	60.4	72.5	82.1	97.4	114.1	132	157.6	
L	67.9	85.3	96.8	107.6	126.1	148	195.6	
E		100.5	111.5	133.1	156.1	177	212.6	
Two End Seals+Top Seal+Bottom Seal+Metal Scraper (SZB) / Two End Seals+Bottom Seal+Metal Scraper (DSB)								
Length of Block \ Size	CR15	CR20	CR25	CR30	CR35	CR45	CR55	
S	48.4	58.5	63.9	74.8	87.1			
N	66.4	79.5	89.1	105.4	123.1	142	167.6	
L	73.9	92.3	103.8	115.6	135.1	158	205.6	
E		107.5	118.5	141.1	165.1	187	222.6	

■ 6-1-8 Self-Lubrication System

(1) Introduction

Self-Lubrication system laminates lubricant on the runway surface. It creates oil film throughout the rolling route to ensure the rollers are properly lubricated. Unlike the previous lubrication loop that just delivers the lubricant to the rollers, the self-lubrication system together with the pumping system ensures the lubrication reliability.

- ◎ Pay attention that if the viscosity of the lubrication oil is not within 100 to 400 cSt, the lubrication effect may be not as expected.
- ◎ Lubrication volume can be appropriately adjusted when self-lubrication system is integrated.
- ◎ Grease nipples are not attached when self-lubrication system is integrated. Please contact our sales staff if grease nipples are required.

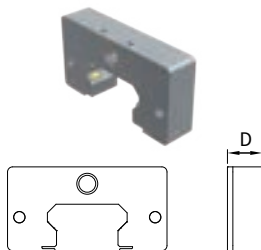


(2) Specifications

Table 6.111 Specifications and size of self-lubrication

Size	D(mm)	V(cm ³)
15	10.3	2.0
20	10.3	2.5
25	10.3	3.0
30	10.3	5.5
35	10.5	8.5
45	13.0	15.0
55	13.0	22.5

D: Thickness of the single self-lubricating component
V: Oil storage capacity



(3) Long-lasting lubrication

It has been experimented that there would be residual oil after 1,500km of travel if recommended viscosity oil was applied. Excess oil in the runway will be recycled by the capillary fiber in the component.

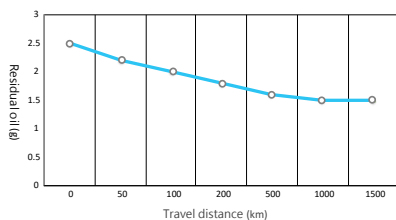


Table 6.112 Durability of self-lubrication

Travel distance (km)	0	50	100	200	500	1000	1500
Residual oil(g)	2.5	2.2	2.0	1.8	1.6	1.5	1.5

* Carriage CR15 integrated with self-lubricating component would still maintain the lubrication performance after 1,500km of travel. If operated in ideal conditions, it would last over 3,000km.

(4) System Compositions

All self-lubrication system consists of 4 kinds of components in table 6.113.

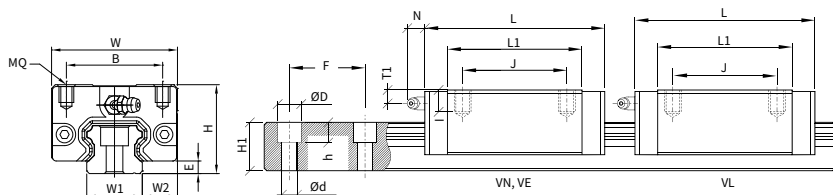
Table 6.113 Compositions

Compositions	Quantity
Self-lubrication system	4
Cover	1
Housing	1
Felt	2

TBI MOTION LINEAR GUIDE

6-1 Ball Chain Type Linear Guide

CRH-V Series Specifications



Model No.	Assembly (mm)				Block Dimension (mm)								
	H	W	W2	E	L	B	J	MQ	I	L1	Oil H	T1	N
CRH15VN	28	34	9.5	3.3	58.6	26	26	M4	6.0	40.2	M4X0.7	9.5	(5.7)
CRH20VN	30	44	12.0	4.5	70.1	32	36	M5	6.5	48.5	M6X1	7.1	(12.3)
CRH20VL	30	44	12.0	4.5	82.9	32	36	M5	6.5	61.3	M6X1	7.1	(12.3)
CRH20VE	30	44	12.0	4.5	98.1	32	50	M5	6.5	76.5	M6X1	7.1	(12.3)
CRH25VN	40	48	12.5	5.8	79.2	35	35	M6	9.0	57.5	M6X1	14.2	(12.2)
CRH25VL	40	48	12.5	5.8	93.9	35	35	M6	9.0	72.2	M6X1	14.2	(12.2)
CRH25VE	40	48	12.5	5.8	108.6	35	50	M6	9.0	86.9	M6X1	14.2	(12.2)
CRH30VN	45	60	16.0	7.0	94.8	40	40	M8	12.0	67.8	M6X1	13.0	(11.7)
CRH30VL	45	60	16.0	7.0	105.0	40	40	M8	12.0	78.0	M6X1	13.0	(11.7)
CRH30VE	45	60	16.0	7.0	130.5	40	60	M8	12.0	103.5	M6X1	13.0	(11.7)
CRH35VN	55	70	18.0	7.5	111.5	50	50	M8	12.0	80.5	M6X1	18.5	(11.5)
CRH35VL	55	70	18.0	7.5	123.5	50	50	M8	12.0	92.5	M6X1	18.5	(11.5)
CRH35VE	55	70	18.0	7.5	153.5	50	72	M8	12.0	122.5	M6X1	18.5	(11.5)
CRH45VN	70	86	20.5	8.9	129.0	60	60	M10	18.0	94.0	M8X1.25	24.4	(10.8)
CRH45VL	70	86	20.5	8.9	145.0	60	60	M10	18.0	110.0	M8X1.25	24.4	(10.8)
CRH45VE	70	86	20.5	8.9	174.0	60	80	M10	18.0	139.0	M8X1.25	24.4	(10.8)
CRH55VN	80	100	23.5	12.7	155.0	75	75	M12	22.0	116.0	M8X1.25	24.0	(10.8)
CRH55VL	80	100	23.5	12.7	193.0	75	75	M12	22.0	154.0	M8X1.25	24.0	(10.8)
CRH55VE	80	100	23.5	12.7	210.0	75	95	M12	22.0	171.0	M8X1.25	24.0	(10.8)

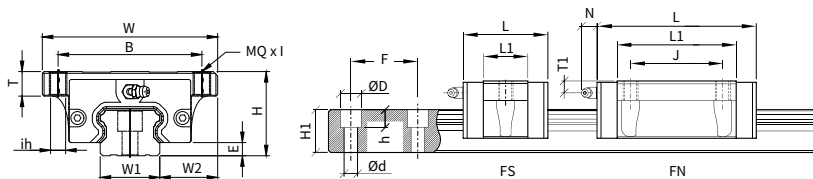
※ This is the standard XNB dust-proof specification. For other optional accessories, please refer to page A164.

Rail Dimension (mm)						Load Rating (kgf)		Static Permissible Moment (kg•mm)			Weight	
W1	H1	F	d	D	h	C	C0	Mx	My	Mz	Block (kg)	Rail (kg/m)
15	13.0	60	4.5	7.5	5.5	1173	2000	13878	11939	11939	0.19	1.28
20	16.3	60	6.0	9.5	8.5	1806	3112	29082	22449	22449	0.31	2.15
20	16.3	60	6.0	9.5	8.5	2347	4031	37653	36837	36837	0.36	2.15
20	16.3	60	6.0	9.5	8.5	2786	4990	46531	56837	56837	0.47	2.15
23	19.2	60	7.0	11.0	9.0	2531	4194	44898	35918	35918	0.45	2.88
23	19.2	60	7.0	11.0	9.0	3255	5388	57755	57959	57959	0.66	2.88
23	19.2	60	7.0	11.0	9.0	3673	6459	69286	83571	83571	0.80	2.88
28	22.8	80	9.0	14.0	12.0	3745	5571	72041	56224	56224	0.91	4.45
28	22.8	80	9.0	14.0	12.0	4847	7214	93367	83776	83776	1.04	4.45
28	22.8	80	9.0	14.0	12.0	5398	8847	114490	136327	136327	1.36	4.45
34	26.0	80	9.0	14.0	12.0	5337	8276	130816	99184	99184	1.50	6.25
34	26.0	80	9.0	14.0	12.0	6673	10347	163469	142449	142449	1.80	6.25
34	26.0	80	9.0	14.0	12.0	7337	12786	202143	233265	233265	2.34	6.25
45	31.1	105	14.0	20.0	17.0	7306	11112	234694	155510	155510	2.28	9.60
45	31.1	105	14.0	20.0	17.0	8684	13214	279184	216531	216531	2.67	9.60
45	31.1	105	14.0	20.0	17.0	10041	16663	351939	344796	344796	3.35	9.60
53	38.0	120	16.0	23.0	20.0	8796	13612	337041	235102	235102	3.42	13.80
53	38.0	120	16.0	23.0	20.0	11867	18255	451837	418469	418469	4.57	13.80
53	38.0	120	16.0	23.0	20.0	16092	25878	640714	658980	658980	5.08	13.80

TBI MOTION LINEAR GUIDE

6-1 Ball Chain Type Linear Guide

CRH-F Series Specifications



A

Linear Guide

Model No.	Assembly (mm)				Block Dimension (mm)											
	H	W	W2	E	L	B	J	MQ	I	ih	T	L1	Oil H	T1	N	
CRH15FN	24	47	16.0	3.3	58.6	38	30	M5	7.0	4.4	7.5	40.2	M4X0.7	5.5	(5.7)	
CRH15FL	24	47	16.0	3.3	66.1	38	30	M5	7.0	4.4	7.5	47.7	M4X0.7	5.5	(5.7)	
CRH20FN	30	63	21.5	4.5	70.1	53	40	M6	8.5	5.4	9.0	48.5	M6X1	7.1	(12.3)	
CRH20FL	30	63	21.5	4.5	82.9	53	40	M6	8.5	5.4	9.0	61.3	M6X1	7.1	(12.3)	
CRH20FE	30	63	21.5	4.5	98.1	53	40	M6	8.5	5.4	9.0	76.5	M6X1	7.1	(12.3)	
CRH25FN	36	70	23.5	5.8	79.2	57	45	M8	9.6	6.8	10.1	57.5	M6X1	10.2	(12.2)	
CRH25FL	36	70	23.5	5.8	93.9	57	45	M8	9.6	6.8	10.1	72.2	M6X1	10.2	(12.2)	
CRH25FE	36	70	23.5	5.8	108.6	57	45	M8	9.6	6.8	10.1	86.9	M6X1	10.2	(12.2)	
CRH30FS	42	90	31.0	7.0	64.2	72	52	M10	11.5	8.6	12.0	37.2	M6X1	10.0	(11.7)	
CRH30FN	42	90	31.0	7.0	94.8	72	52	M10	11.5	8.6	12.0	67.8	M6X1	10.0	(11.7)	
CRH30FL	42	90	31.0	7.0	105.0	72	52	M10	11.5	8.6	12.0	78.0	M6X1	10.0	(11.7)	
CRH30FE	42	90	31.0	7.0	130.5	72	52	M10	11.5	8.6	12.0	103.5	M6X1	10.0	(11.7)	
CRH35FS	48	100	33.0	7.5	75.5	82	62	M10	13.5	8.6	14.0	44.5	M6X1	11.5	(11.5)	
CRH35FN	48	100	33.0	7.5	111.5	82	62	M10	13.5	8.6	14.0	80.5	M6X1	11.5	(11.5)	
CRH35FL	48	100	33.0	7.5	123.5	82	62	M10	13.5	8.6	14.0	92.5	M6X1	11.5	(11.5)	
CRH35FE	48	100	33.0	7.5	153.5	82	62	M10	13.5	8.6	14.0	122.5	M6X1	11.5	(11.5)	
CRH45FL	60	120	37.5	8.9	145.0	100	80	M12	15.5	10.6	16.0	110.0	M8X1.25	14.4	(10.8)	
CRH45FE	60	120	37.5	8.9	174.0	100	80	M12	15.5	10.6	16.0	139.0	M8X1.25	14.4	(10.8)	
CRH55FN	70	140	43.5	12.7	155.0	116	95	M14	18.5	12.6	19.0	116.0	M8X1.25	14.0	(10.8)	
CRH55FL	70	140	43.5	12.7	193.0	116	95	M14	18.5	12.6	19.0	154.0	M8X1.25	14.0	(10.8)	
CRH55FE	70	140	43.5	12.7	210.0	116	95	M14	18.5	12.6	19.0	171.0	M8X1.25	14.0	(10.8)	

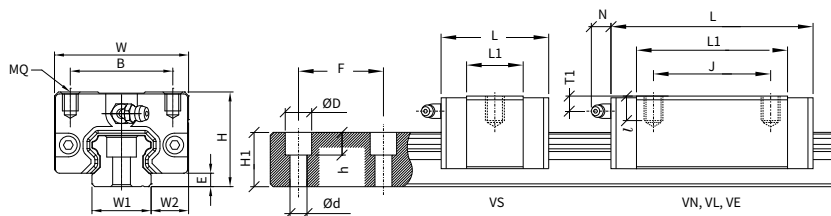
※ This is the standard XNB dust-proof specification. For other optional accessories, please refer to page A164.

Rail Dimension (mm)						Load Rating (kgf)		Static Permissible Moment (kg•mm)			Weight	
W1	H1	F	d	D	h	C	C0	Mx	My	Mz	Block (kg)	Rail (kg/m)
15	13	60	4.5	7.5	5.5	1173	2000	13878	11939	11939	0.21	1.28
15	13	60	4.5	7.5	5.5	1418	2418	16735	17245	17245	0.23	1.28
20	16	60	6.0	9.5	8.5	1806	3112	29082	22449	22449	0.40	2.15
20	16	60	6.0	9.5	8.5	2347	4031	37653	36837	36837	0.46	2.15
20	16	60	6.0	9.5	8.5	2786	4990	46531	56837	56837	0.61	2.15
23	19	60	7.0	11.0	9.0	2531	4194	44898	35918	35918	0.57	2.88
23	19	60	7.0	11.0	9.0	3255	5388	57755	57959	57959	0.72	2.88
23	19	60	7.0	11.0	9.0	3673	6459	69286	83571	83571	0.89	2.88
28	23	80	9.0	14.0	12.0	1857	2755	35714	15306	15306	0.80	4.45
28	23	80	9.0	14.0	12.0	3745	5571	72041	56224	56224	1.10	4.45
28	23	80	9.0	14.0	12.0	4847	7214	93367	83776	83776	1.34	4.45
28	23	80	9.0	14.0	12.0	5398	8847	114490	136327	136327	1.66	4.45
34	26	80	9.0	14.0	12.0	2673	4153	65612	27449	27449	1.00	6.25
34	26	80	9.0	14.0	12.0	5337	8276	130816	99184	99184	1.50	6.25
34	26	80	9.0	14.0	12.0	6673	10347	163469	142449	142449	1.90	6.25
34	26	80	9.0	14.0	12.0	7337	12786	202143	233265	233265	2.54	6.25
45	31	105	14.0	20.0	17.0	8684	13214	279184	216531	216531	2.68	9.60
45	31	105	14.0	20.0	17.0	10041	16663	351939	344796	344796	3.42	9.60
53	38	120	16.0	23.0	20.0	8796	13612	337041	235102	235102	3.44	13.80
53	38	120	16.0	23.0	20.0	11867	18255	451837	418469	418469	4.63	13.80
53	38	120	16.0	23.0	20.0	16092	25878	640714	658980	658980	5.16	13.80

TBI MOTION LINEAR GUIDE

6-1 Ball Chain Type Linear Guide

CRS-V Series Specifications



Model No.	Assembly (mm)				Block Dimension (mm)								
	H	W	W2	E	L	B	J	MQ	I	L1	Oil H	T1	N
CRS15VS	24	34	9.5	3.3	40.6	26	/	M4	4.8	22.2	M4X0.7	5.5	(5.7)
CRS15VN	24	34	9.5	3.3	58.6	26	26	M4	4.8	40.2	M4X0.7	5.5	(5.7)
CRS15VL	24	34	9.5	3.3	66.1	26	26	M4	4.8	47.7	M4X0.7	5.5	(5.7)
CRS20VS	28	42	11.0	4.5	49.1	32	/	M5	5.5	27.5	M6X1.0	5.1	(12.3)
CRS20VN	28	42	11.0	4.5	70.1	32	32	M5	5.5	48.5	M6X1.0	5.1	(12.3)
CRS25VS	33	48	12.5	5.8	54.0	35	/	M6	6.8	32.3	M6X1.0	7.2	(12.2)
CRS25VN	33	48	12.5	5.8	79.2	35	35	M6	6.8	57.5	M6X1.0	7.2	(12.2)
CRS30VS	42	60	16.0	7.0	64.2	40	/	M8	10.0	37.2	M6X1.0	10.0	(11.7)
CRS30VN	42	60	16.0	7.0	94.8	40	40	M8	10.0	67.8	M6X1.0	10.0	(11.7)
CRS30VL	42	60	16.0	7.0	105.0	40	40	M8	10.0	78.0	M6X1.0	10.0	(11.7)
CRS30VE	42	60	16.0	7.0	130.5	40	60	M8	10.0	103.5	M6X1.0	10.0	(11.7)
CRS35VS	48	70	18.0	7.5	75.5	50	/	M8	10.0	44.5	M6X1.0	11.5	(11.5)
CRS35VN	48	70	18.0	7.5	111.5	50	50	M8	10.0	80.5	M6X1.0	11.5	(11.5)
CRS35VL	48	70	18.0	7.5	123.5	50	50	M8	10.0	92.5	M6X1.0	11.5	(11.5)
CRS35VE	48	70	18.0	7.5	153.5	50	72	M8	10.0	122.5	M6X1.0	11.5	(11.5)
CRS45VN	60	86	20.5	8.9	129.0	60	60	M10	15.5	94.0	M8X1.25	14.4	(10.8)
CRS45VL	60	86	20.5	8.9	145.0	60	60	M10	15.5	110.0	M8X1.25	14.4	(10.8)
CRS45VE	60	86	20.5	8.9	174.0	60	80	M10	15.5	139.0	M8X1.25	14.4	(10.8)
CRS55VN	70	100	23.5	12.7	155.0	75	75	M12	18.0	116.0	M8X1.25	14.0	(10.8)
CRS55VL	70	100	23.5	12.7	193.0	75	75	M12	18.0	154.0	M8X1.25	14.0	(10.8)
CRS55VE	70	100	23.5	12.7	210.0	75	95	M12	18.0	171.0	M8X1.25	14.0	(10.8)

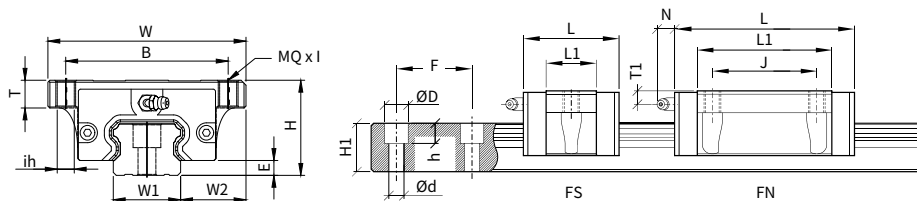
※ This is the standard XNB dust-proof specification. For other optional accessories, please refer to page A164.

Rail Dimension (mm)						Load Rating (kgf)		Static Permissible Moment (kg•mm)			Weight	
W1	H1	F	d	D	h	C	C0	Mx	My	Mz	Block (kg)	Rail (kg/m)
15	13.0	60	4.5	7.5	5.5	582	1000	6939	3265	3265	0.10	1.28
15	13.0	60	4.5	7.5	5.5	1173	2000	13878	11939	11939	0.17	1.28
15	13.0	60	4.5	7.5	5.5	1418	2418	16735	17245	17245	0.18	1.28
20	16.3	60	6.0	9.5	8.5	929	1602	14898	6531	6531	0.17	2.15
20	16.3	60	6.0	9.5	8.5	1806	3112	29082	22449	22449	0.26	2.15
23	19.2	60	7.0	11.0	9.0	1296	2143	22959	10306	10306	0.21	2.88
23	19.2	60	7.0	11.0	9.0	2531	4194	44898	35918	35918	0.38	2.88
28	22.8	80	9.0	14.0	12.0	1857	2755	35714	15306	15306	0.50	4.45
28	22.8	80	9.0	14.0	12.0	3745	5571	72041	56224	56224	0.80	4.45
28	22.8	80	9.0	14.0	12.0	4847	7214	93367	83776	83776	0.94	4.45
28	22.8	80	9.0	14.0	12.0	5398	8847	114490	136327	136327	1.16	4.45
34	26.0	80	9.0	14.0	12.0	2673	4153	65612	27449	27449	0.80	6.25
34	26.0	80	9.0	14.0	12.0	5337	8276	130816	99184	99184	1.20	6.25
34	26.0	80	9.0	14.0	12.0	6673	10347	163469	142449	142449	1.40	6.25
34	26.0	80	9.0	14.0	12.0	7337	12786	202143	233265	233265	1.84	6.25
45	31.1	105	14.0	20.0	17.0	7306	11112	234694	155510	155510	1.64	9.60
45	31.1	105	14.0	20.0	17.0	8684	13214	279184	216531	216531	1.93	9.60
45	31.1	105	14.0	20.0	17.0	10041	16663	351939	344796	344796	2.42	9.60
53	38.0	120	16.0	23.0	20.0	8796	13612	337041	235102	235102	2.67	13.80
53	38.0	120	16.0	23.0	20.0	11867	18255	451837	418469	418469	3.57	13.80
53	38.0	120	16.0	23.0	20.0	16092	25878	640714	658980	658980	3.97	13.80

TBI MOTION LINEAR GUIDE

6-1 Ball Chain Type Linear Guide

CRS-F Series Specifications



A

Linear Guide

Model No.	Assembly (mm)				Block Dimension (mm)											
	H	W	W2	E	L	B	J	MQ	I	ih	T	L1	Oil H	T1	N	
CRS15FS	24	52	18.5	3.3	40.6	41	/	M5	7	4.4	7.5	22.2	M4X0.7	5.5	(5.7)	
CRS15FN	24	52	18.5	3.3	58.6	41	26	M5	7	4.4	7.5	40.2	M4X0.7	5.5	(5.7)	
CRS20FS	28	59	19.5	4.5	49.1	49	/	M6	6.5	5.4	7.0	27.5	M6X1	5.1	(12.3)	
CRS20FN	28	59	19.5	4.5	70.1	49	32	M6	6.5	5.4	7.0	48.5	M6X1	5.1	(12.3)	
CRS25FS	33	73	25.0	5.8	54.0	60	/	M8	6.6	6.8	7.1	32.3	M6X1	7.2	(12.3)	
CRS25FN	33	73	25.0	5.8	79.2	60	35	M8	6.6	6.8	7.1	57.5	M6X1	7.2	(12.3)	

※ This is the standard XNB dust-proof specification. For other optional accessories, please refer to page A164.

Rail Dimension (mm)						Load Rating (kgf)		Static Permissible Moment (kg•mm)			Weight	
W1	H1	F	d	D	h	C	C0	Mx	My	Mz	Block (kg)	Rail (kg/m)
15	13.0	60	4.5	7.5	5.5	582	1000.0	6939	3265	3265	0.12	1.28
15	13.0	60	4.5	7.5	5.5	1173	2000.0	13878	11939	11939	0.19	1.28
20	16.3	60	6.0	9.5	8.5	929	1602.0	22959	10306	10306	0.18	2.15
20	16.3	60	6.0	9.5	8.5	1806	3112.2	29082	22449	22449	0.31	2.15
23	19.2	60	7.0	11.0	9.0	1296	2142.9	22959	10306	10306	0.33	2.88
23	19.2	60	7.0	11.0	9.0	2531	4193.9	44898	35918	35918	0.50	2.88

6-1 Ball Chain Type Linear Guide

6-1-9 Grease Nipples

Table 6.1.14 Standard Grease Nipples

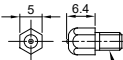
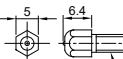
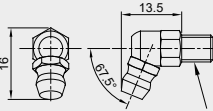
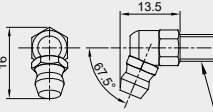
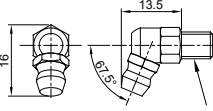
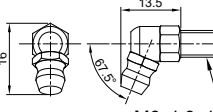
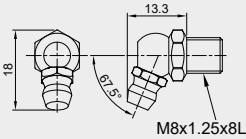
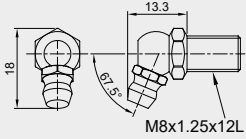
Model	Accessory Code	Grease Nipple Code	Size
CR15	XNB, UNB, SUB, ZUB	ND-01	 M4x0.7x5L
	DUB, ZNB, SZB, DSB	ND-02	 M4x0.7x8L
CR20, CR25	XNB, UNB, SUB, ZUB	ND-03	 M6x1.0x7L
	DUB, ZNB, SZB, DSB	ND-04	 M6x1.0x10L
CR30, CR35	XNB, UNB, SUB, ZUB	ND-03	 M6x1.0x7L
	DUB, ZNB, SZB, DSB	ND-05	 M6x1.0x12L

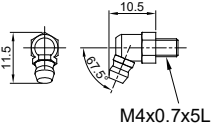
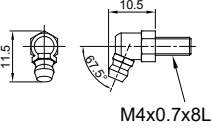
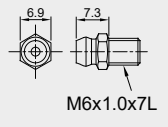
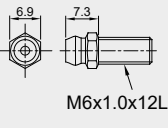
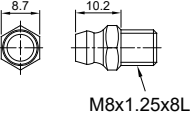
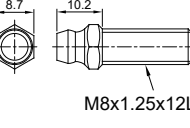
Table 6.1.14 Standard Grease Nipples

Model	Accessory Code	Grease Nipple Code	Size
CR45, CR55	XNB, UNB, SUB, ZUB	ND-06	
	DUB, ZNB, SZB, DSB	ND-07	

TBI MOTION LINEAR GUIDE

6-1 Ball Chain Type Linear Guide

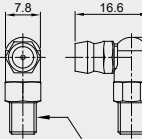



Table 6.1.15 Special Grease Nipples

Model	Accessory Code	Grease Nipple Code	Size
CR15	XNB, UNB, SUB, ZUB	ND-08	 <p>M4x0.7x5L</p>
	DUB, ZNB, SZB, DSB	ND-09	 <p>M4x0.7x8L</p>
CR20, CR25, CR30, CR35	XNB, UNB, SUB, ZUB	ND-10	 <p>M6x1.0x7L</p>
	DUB, ZNB, SZB, DSB	ND-11	 <p>M6x1.0x12L</p>
CR45, CR55	XNB, UNB, SUB, ZUB	ND-12	 <p>M8x1.25x8L</p>
	DUB, ZNB, SZB, DSB	ND-13	 <p>M8x1.25x12L</p>

A

Linear Guide

Table 6.1.15 Special Grease Nipples

Model	Accessory Code	Grease Nipple Code	Size
CR20, CR25, CR30, CR35	XNB, UNB, SUB, ZUB	ND-14	 <p>M6x1.0x7L</p>
	DUB, ZNB, SZB, DSB	ND-15	 <p>M6x1.0x12L</p>
CR45, CR55	XNB, UNB, SUB, ZUB	ND-16	 <p>M8x1.25x8L</p>
	DUB, ZNB, SZB, DSB	ND-17	 <p>M8x1.25x12L</p>

TBI MOTION LINEAR GUIDE

6-1 Ball Chain Type Linear Guide

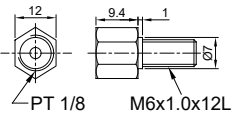
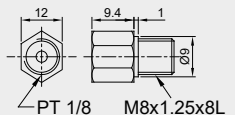
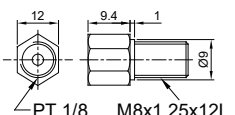
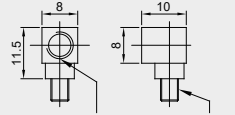
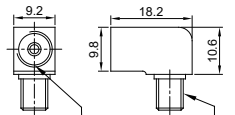
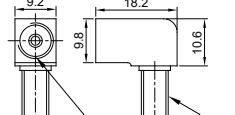
Table 6.1.16 Special Lubrication Coupler

Model	Accessory Code	Grease Nipple Code	Size
CR15	XNB, UNB, SUB, ZUB	ND-18	
CR20, CR25, CR30, CR35	XNB, UNB, SUB, ZUB	ND-19	
	DUB, ZNB, SZB, DSB	ND-20	
CR45, CR55	XNB, UNB, SUB, ZUB	ND-21	
	DUB, ZNB, SZB, DSB	ND-22	
CR20, CR25, CR30, CR35	XNB, UNB, SUB, ZUB	ND-23	

A

Linear Guide

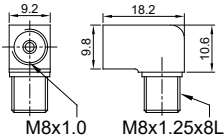
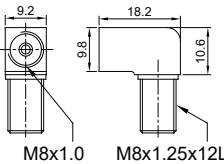
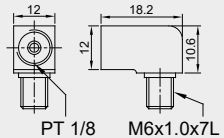
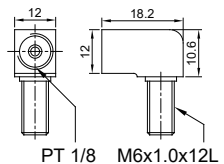
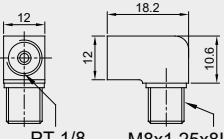
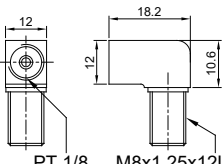
Table 6.116 Special Lubrication Coupler

Model	Accessory Code	Grease Nipple Code	Size
CR25, CR30, CR35	DUB, ZNB, SZB, DSB	ND-24	
CR45, CR55	XNB, UNB, SUB, ZUB	ND-25	
CR45, CR55	DUB, ZNB, SZB, DSB	ND-26	
CR15	XNB, UNB, SUB, ZUB	ND-27	
CR20, CR25, CR30, CR35	XNB, UNB, SUB, ZUB	ND-28	
	DUB, ZNB, SZB, DSB	ND-29	

TBI MOTION LINEAR GUIDE

6-1 Ball Chain Type Linear Guide

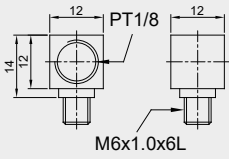
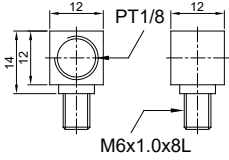
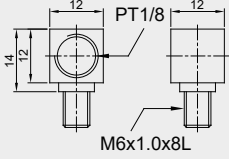
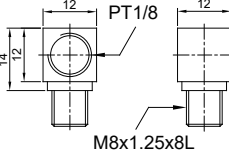
Table 6.1.16 Special Lubrication Coupler

Model	Accessory Code	Grease Nipple Code	Size
CR45, CR55	XNB, UNB, SUB, ZUB	ND-30	
	DUB, ZNB, SZB, DSB	ND-31	
CR20, CR25, CR30, CR35	XNB, UNB, SUB, ZUB	ND-32	
CR25, CR30, CR35	DUB, ZNB, SZB, DSB	ND-33	
CR45, CR55	XNB, UNB, SUB, ZUB	ND-34	
CR45, CR55	DUB, ZNB, SZB, DSB	ND-35	

A

Linear Guide

Table 6.1.16 Special Lubrication Coupler

Model	Accessory Code	Grease Nipple Code	Size
CR20, CR25	XNB, UNB, SUB, ZUB	ND-36	
CR20	DUB, ZNB, SZB, DSB	ND-37	
CR30, CR35	XNB, UNB, SUB, ZUB	ND-37	
CR45, CR55	XNB, UNB, SUB, ZUB	ND-38	

6-1 Ball Chain Type Linear Guide

Lubrication tool

With different size greaser spouts, grease gun is capable to fill lubrication to all types and sizes of linear guides.

Special accessories are available for smaller linear guides. Please select appropriate accessories according to the type and space.

Lubrication accessories

The adaptor tube, with different accessories attached, may be applicable for refill in various ways.

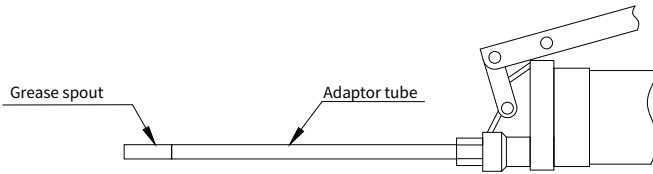


Table 6.117 Applicable lubrication accessories for each linear guide type

Type	Dimensions
E Type (PT1/8-M5)	

Table 6.118 Grease spout

Type	Dimensions	Linear Guide Type
N Type		CR15
P Type		CR15
R Type		CR15

※ Lubrication accessory kit includes adaptor tube and grease spouts, but not the grease gun.